

# Heavyduty Type

## Pneumatic Shear Knifeholder

# MT-A880

**MT-A880** is our versatile heavy-duty knife-holder that is suitable for a wide range of shear slitting application. It combines extremely durable knife-holder body and 200mm top blade handle maximum slitting speed up to 2000M/min. Ideal design of micro depth adjustment, individual stroke valve, self-flow control, cant angle adjust, reversible blade cartridge, mounting bracket, are a key benefit to reduce setting time and deliver convenient operation.

MT-A880 provides a highly reliable slitting performance major application is for thicker, high slitting speed paper, plastic film, non-woven fibers and others.

### » Feature

- Min slitting width 80mm
- Self flow control
- Micro depth adjustment
- Individual control valve
- Cant angle adjustment
- Changeable blade cartridge
- Changeable mounting bracket

### » Specification

- Min. slitting width : 80mm
- Max. slitting speed : 2000M/min (1)
- Down stroke range : 0~25mm
- Side contact range : 0~3mm
- Top blade dia. :  $\phi$ 200mm
- Guide-bar : GB03

(1) Max slitting speed depends on different material and the condition will be changed.



MT-A880

MOTOKNIFE

# MT-A880 Dimension drawing

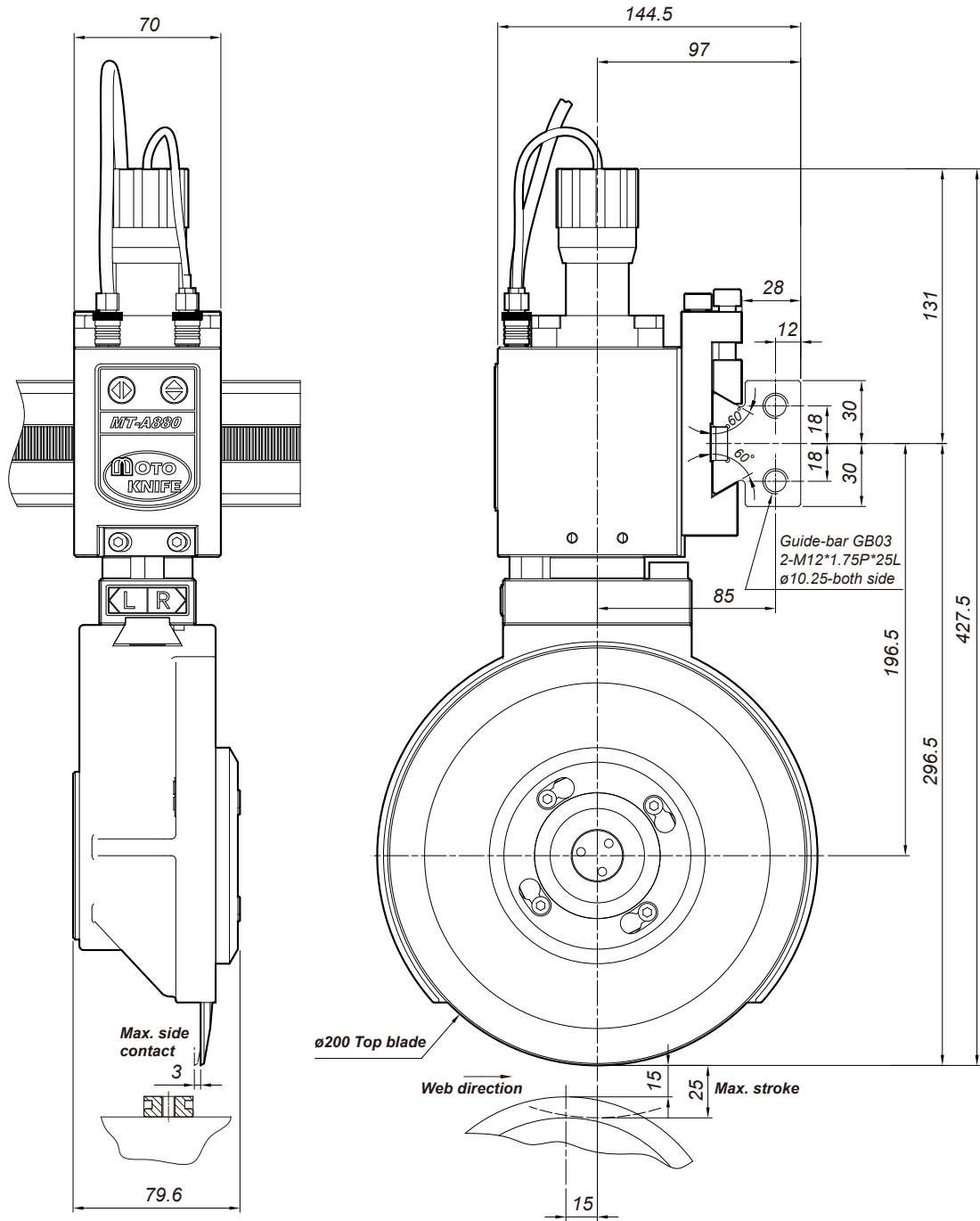

# Blade dimension drawing

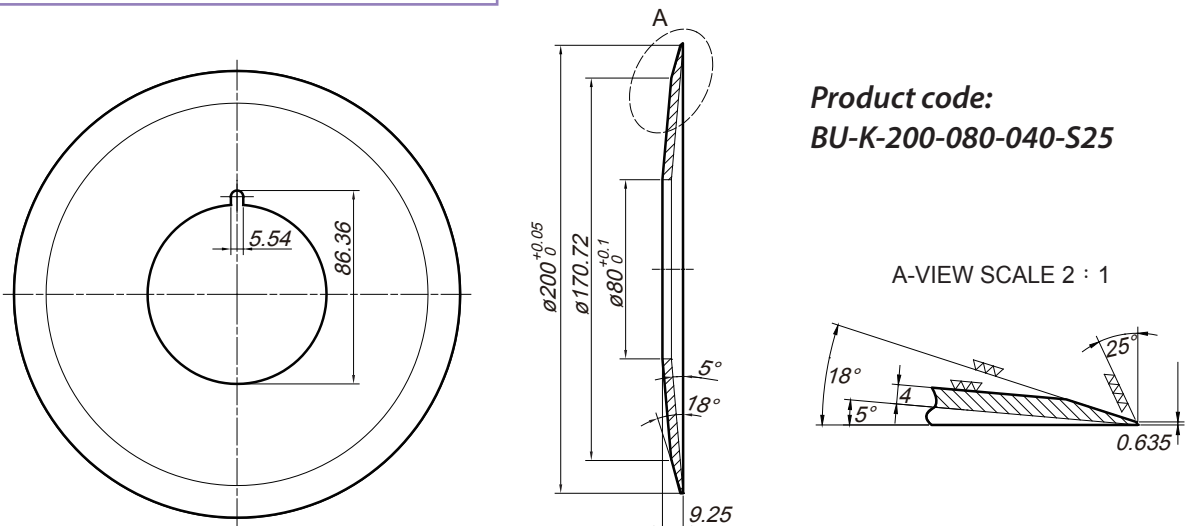

Product code:  
BU-K-200-080-040-S25

A-VIEW SCALE 2 : 1

## Different web path arrange

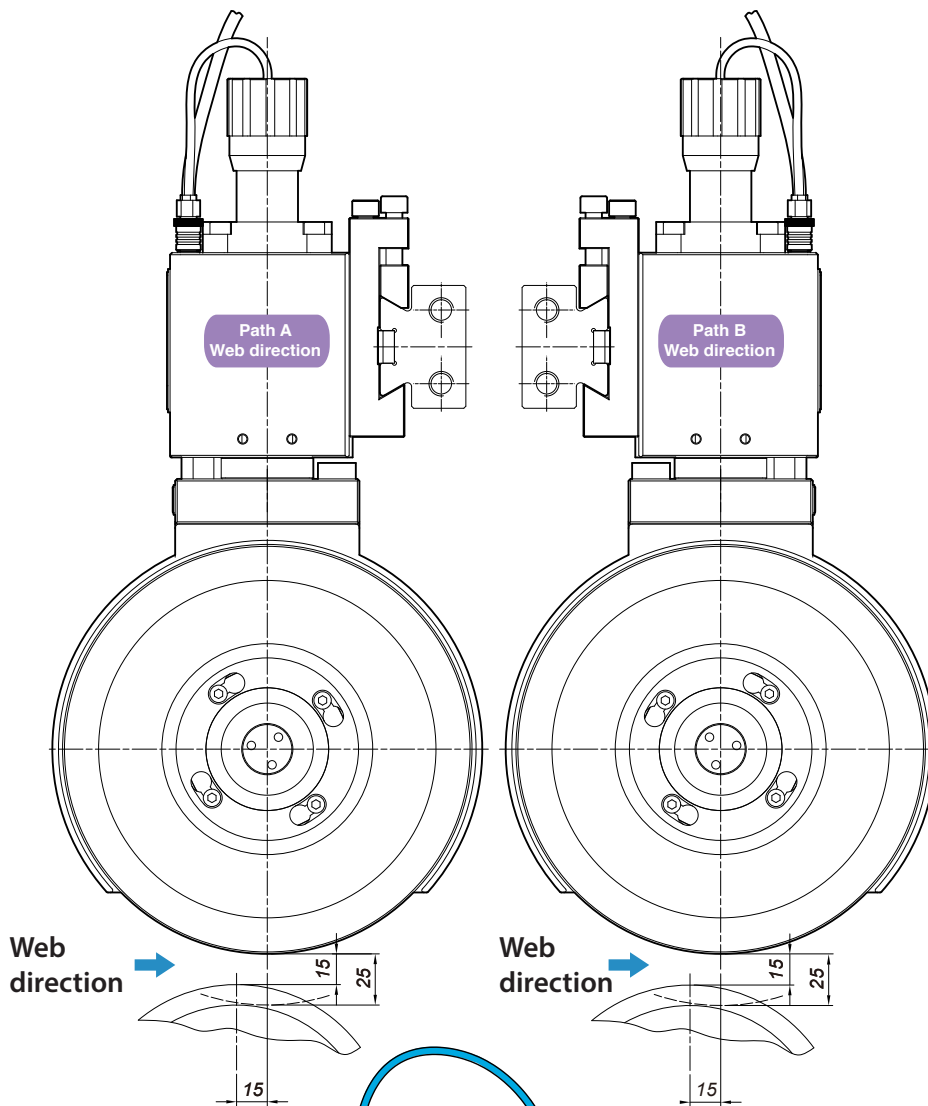

## Different Web Path

Easily changeable cant angle can is for different web path direction application, in order to obtain better slitting effect corrcet cant angle setup is very important!!

## Knife-holder direction arrange

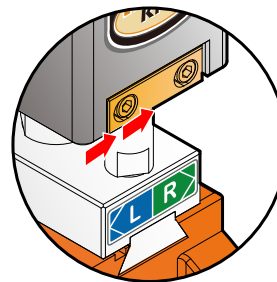
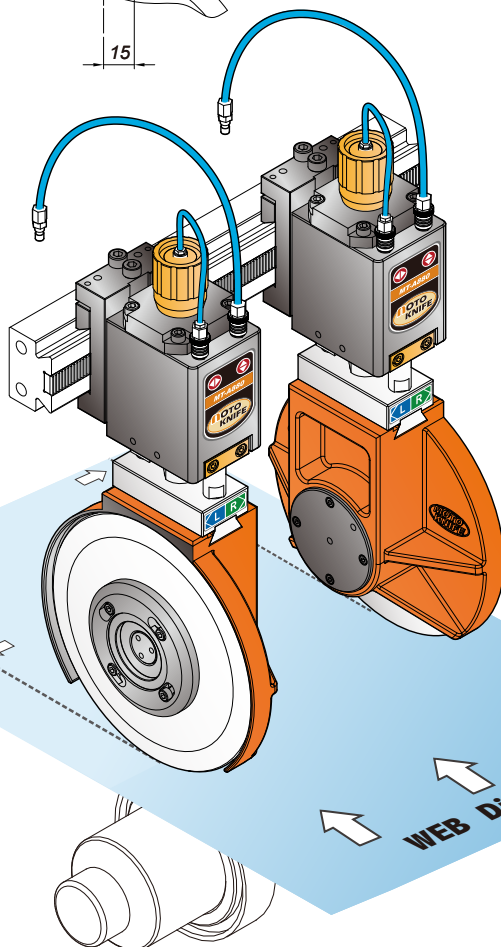

Path A

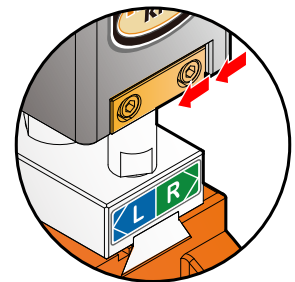

Path B

## Cant angle adjust

For different web path application now is more easily to adjust. Unscrew angle plate and rotate bottom knifeholder for different web path direction and to get better efficiency result.

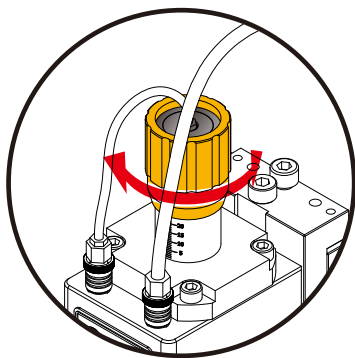

## Depth adjust

Using depth adjust screw can easily control down stroke overlap distance between top and bottom blade, it is helpful for overlap compensation when blade wear.

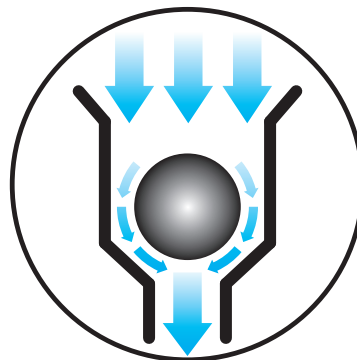

## Internal air flow control

Patent design with internal air flow control, you can directly connect air source without air throttle valve and never worry too much air flow to damage blade!!

## Saving setting time

Using gear and rack on guide-bar to adjust knifeholder position, make setting correct position easy and fast.

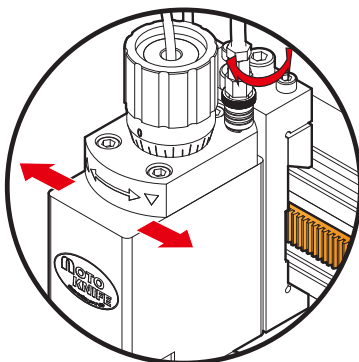

## Individual valve control

More convenient for down stroke and side contact individual valve control, it can be operation under automatic action or separate when arrange position.

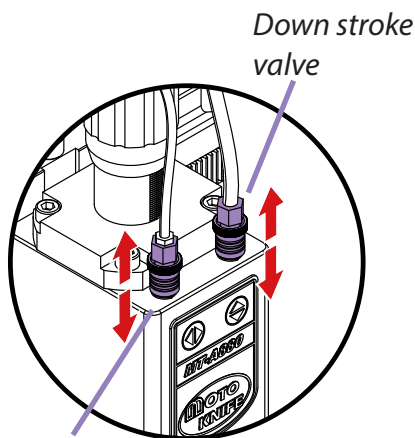

Side stroke valve

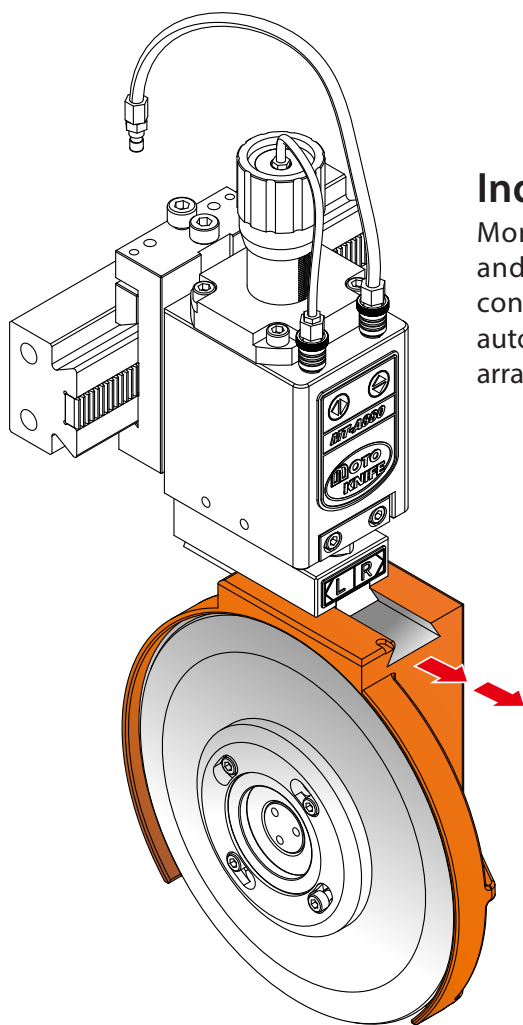

## Reversible blade cartridge

Depending on different application, it can be reverse cartridge 180 degree to setting proper slitting position by user and extend bottom blade life time.

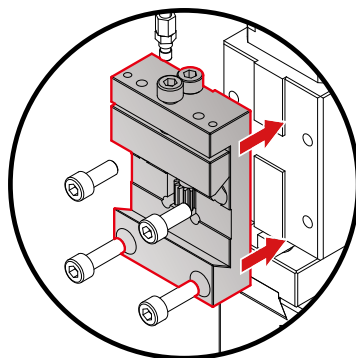

## Mounting bracket

Changeable mounting bracket adjustable flexible guidebar system. We can accept special order different mounting bracket for your existing system.

## Slitting Products Available:

Various Papers	kraft paper, silicone paper, releasing paper, decoration wall paper, masking paper, adhesive paper, thick paper board, corrugated carton paper, sand paper.
Various Plastic films	flexible laminated films, soft & rigid PVC films, BOPP, PET, PE, PS, LDPE, PLA, SBS, various adhesive tape...etc.
Cloth & fabrics	non-woven cloth, synthetic leather, natural cotton, mesh cloth, medical cloth, label cloth...etc.
Metal films	copper foil, aluminum foil.



MOTO, TAIWAN  
32652 No.65 Lane 155, Xinjiang Rd.,  
Yangmei District, Taoyuan City, Taiwan  
TEL:+886-3-4753005  
FAX:+886-3-4754797  
E-mail:service@motoknife.com  
http://www.motoknife.com

MOTO, CHINA  
No.8 Zhang Jia Road, Huang Du Town,  
JiaDing Area, Shanghai, China  
TEL:+86-21-69596169  
FAX:+86-21-69596163  
E-mail:motokevin@126.com



MT-A880

MOTOKNIFE